

Neutral messenger network suspension and anchoring

Anchoring assembly

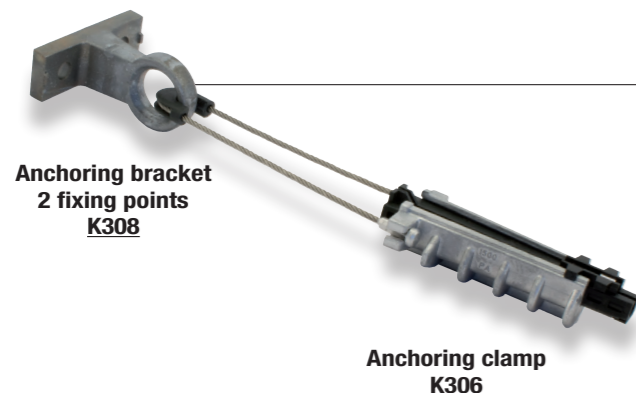

Application

This anchoring assembly is designed for the 1500daN single or double anchoring of A.B.C. (Aerial Bundled Conductors) with insulated neutral messenger of 54.6 and 70mm² sections. It comprises a bracket supporting one or two anchoring clamps.

Description

Anchoring clamp:

- The body is made of aluminium alloy.
- The cleats are made of UV resistant synthetic material. They are captive.
- The stainless steel flexible linking cable is captive. It is equipped with a resistant, insulated and movable saddle.
- Fixing the insulated neutral messenger is ensured by cleats without damaging the insulation.

Anchoring bracket

- The bracket is made of aluminium alloy and permits single or double anchoring.
- Fixing on poles is ensured by one or two 14 or 16mm diameter bolts with suitable washers or using two 20x0.7mm stainless steel straps.

This anchoring assembly meets the criteria of the **NF C 33-041** and **EN 50-483-3** standards.

Installation

- Fix the bracket on the pole using one or two 14 or 16mm diameter bolts with suitable washers or using two 20x0.7mm stainless steel straps.
- Open the A.B.C. where the installation has to be done.
- Slide the cleats backward.
- Insert the neutral messenger between the cleats.
- Push the cleats in the clamp while keeping the neutral messenger in place.
- Anchor the clamp on the bracket.
- Additional tightening is achieved automatically by the cleats.

Code	Designation	Weight (kg)	Sales unit
K306	ANCHORING CLAMP - PA 1500	0.410	20
K308	ANCHORING BRACKET - CA 1500 - 2FP	0.281	30

Suspension assembly



Suspension assembly
ES 1500 (50 - 95mm²): **K277**



Fuse suspension assembly ESF 715
(50 - 70mm²): **K283**

Application

This suspension assembly is designed for suspending the low voltage A.B.C. (Aerial Bundled Conductors) with insulated neutral messenger of 50 - 95mm² sections for code **K277** and 50 - 70mm² sections for code **K283**.

It comprises a movable link system, a suspension clamp and a bracket.

2 standard suspension assemblies are available:

- ES 1500,
- ESF 715 equipped with a fuse element (breaking 715 ± 65daN).

The fuse element can be factory calibrated between 500 and 1 200daN. It is designed to break when an abnormal effort is applied on the A.B.C. The cable drops without causing the pole to break (i.e.: tree falling on to a power line). The cable can be quickly put back in position thanks to the installation of a new clamp on the bracket still in place.

Description

The movable link system and the bracket are delivered in a full set.

Movable link system:

- The body is made of UV resistant, glass fibre reinforced synthetic material and adds insulation between the pole and the cables.
- The design facilitates longitudinal and transversal movement of the suspension clamp body.
- The ESF 715 incorporates the fuse element.

Bracket:

- The bracket is made of aluminium alloy.
- Fixing on poles is ensured by a 14 or 16mm diameter bolt with a suitable washer or using two 20x0.7mm stainless steel straps.

This suspension assembly meets the criteria of **NF C 33-040** and **EN 50-483**.

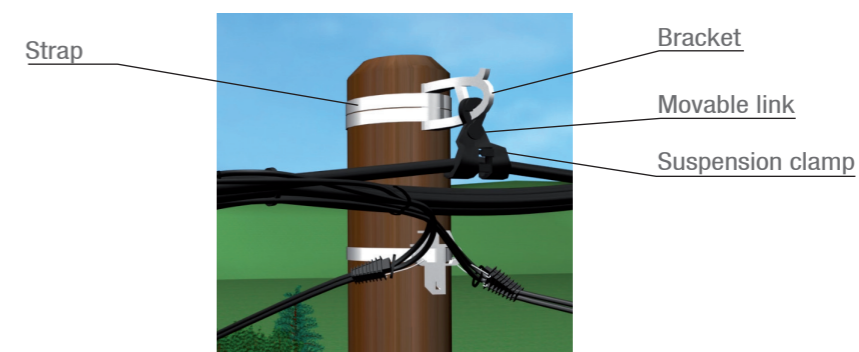

Code	Designation	Weight (kg)	Sales unit
K277	SUSPENSION ASSEMBLY [50-95] - ES 1500	0.456	20
K283	FUSE SUSPENSION ASSEMBLY [50-70] - ESF 715	0.438	20
K280	SPARE PART - PS + LM 715	0.210	1

- Notes:
- Contact us for any other breaking values for the fuse element.
 - Fixing with bolts and washers or stainless steel straps must be ordered separately.
 - The insulated tie must be ordered separately.

SEE SHEET
OVERHEAD / Mechanical fixing / Stainless steel strap